

Data of Issue : December 5th, 2013

SPECIFICATIONS	
Product Name	LT070ME05000
	-

Approval Signature

Accepted by : _____

Date : _____

Japan Display Inc.

Proposed by : _____

Revision History

(A sheet refers to the sheet number after revision)

Date	Rev.	Sheet	Contents	Reason
2013/12/05	1.0	-	NEW	-

Caution and Handling Precaution

For your end users' safety, it is strongly advised that the items with "*" should be included in the instruction manual of the system which may be issued by your organization.

Japan Display always endeavors to maintain sufficient quality in process of designing and manufacturing. However, to avoid causing extended damages such as accidents resulting in injury or death, fire, or social damages if the LCD module fails, take into consideration safe design such as redundant design, fire-spreading prevention design, over-current prevention design, or malfunction prevention design etc. as a whole set.

For Safety



Warning

The following warning indicates a potentially hazardous situation which could result in death or serious injury if you do not follow instructions.

1) SPECIAL PURPOSES

Japan Display's Standard LCD modules described in this Specification are not customized for applying to equipments (for example: nuclear control systems, airplanes and space vehicles, combustion control systems, various safeguards, medical equipment etc.) of which failures or malfunctions may directly threaten a human life or hurt a human body. When using them for the above equipments, consult with our company beforehand.

Understand that our company cannot take responsibility for the damage etc. occurred by use without consultation.



Caution

The following caution indicates a potentially hazardous situation which may result in minor injury or moderate injury, with incorrect usage.

*1) DISASSEMBLING OR MODIFICATION

DO NOT DISASSEMBLE OR MODIFY the modules. Disassembling the module may result in an electric shock.

Sensitive parts inside LCD module may be damaged, and dusts or scratches may cause burning or breakage of circuits or parts or surface damage of display. Japan Display does not warrant the modules, if customer disassembled or modified them.

*2) BREAKAGE OF LCD PANEL

DO NOT INGEST liquid crystal material, DO NOT INHALE this material, and DO NOT PERMIT this material to contact the skin, if glass of LCD panel is broken.

If liquid crystal material contacts the skin, mouth or clothing, take the following actions immediately.

In case contact to the eye or mouth, rinse with large amount of running water for more than 15 minutes. In case contact to the skin or clothing, wipe it off immediately and wash with soap and large amount of running water for more than 15 minutes.

The skin or clothing may be damaged if liquid crystal material is left adhered.

In case ingestion, rinse out the mouth well with water. After spewing up by drinking large amount of water, get medical treatment.

*3) GLASS OF LCD PANEL

BE CAREFUL WITH CHIPS OF GLASS that may cause injuring fingers or skin, when the glass is broken.

The LCD module has the structure where a plastic film is stuck on a glass surface and glass cannot disperse easily. However, touching a cut surface may cause injuries.

4) ABSOLUTE MAXIMUM RATINGS

DO NOT EXCEED the absolute maximum ratings specified in this Specification. These are the rated values that must not exceed for a LCD module by any means. Since the parts used as a circuit are damaged by fire or breakage and the characteristic may not be recovered when exceeding this rating, take into consideration the variation in ambient temperature, input signal change, and dispersed specification of electric parts etc., and design not to exceed LCD module absolute maximum ratings.

5) POWER PROTECTION CIRCUIT

Employ protection circuit for power supply, for LCD module failures according to the operating condition of a set.

A suitable protection circuit should be applied, based on each system design.

A fuse is not fitted to this module. Therefore, without a suitable power-supply protection device, dust or partial circuit failure may cause overheating and/or burning, which may lead to injury.

6) DISPOSAL

Always comply with all applicable environmental regulations, when discarding the LCD module.

7) EDGES OF PARTS

Be careful about handling edge of glass parts and touch panel to avoid injuring.

For designing the system, give special consideration that the wiring and parts do not touch those edges.

8) RECOMMENDED OPERATING CONDITIONS

Don't exceed "the recommended operation conditions" in this specification. (The LCD module should be used within "the recommended operation conditions".)

The performance and quality of the LCD module are warranted only when the LCD module is used within "the recommended operation conditions". Japan Display never warrants the performance and quality of the LCD module when you use the LCD module over "the recommended operation conditions", although within "the absolute maximum rating".

To use the LCD module over "the recommended operation conditions" may have bad influence on the characteristics and reliability of the LCD module and may shorten the life of the LCD module.

Therefore, when designing the whole set, not to be over "the recommended operation conditions", you should fully take care of supply voltage change, characteristic of connection parts, surge of input-and-output line, and surrounding temperature.

For Designing the System**2-1 DESIGNING ENCLOSURE****1) ASSEMBLY**

When the module is assembled into the set, consider the optimum design to prevent module from stress.

***2) TWIST/WARP**

When assembling a LCD module in a set and using the set, be careful not to apply stress, such as twist or warp, on the LCD module at designing an enclosure of the set. Twist or warp may cause LCD module failures.

When FPC is bent, FPC radius of curvature should be more than value of recommendation. When a set is designed, ensure that bending and twisting pressures are not applied to the FPC connector.

3) DESIGN ON THE REAR OF A LCD MODULE

Design a set so that the LCD module rear is not pressed by a set enclosure or a cable, etc. Pressing the LCD module rear deforms a panel etc. and may cause ununiformity in a display.

4) MOUNTING PARTS

Make sure to design not to be added strong external force on the mounting parts of LCD module. When the parts area

stressed, there is a case that drop of some parts and electric short circuit would be cased.

5) GAS GENERATED FROM THE PART MATERIAL FOR A SET

Some plastic materials and shock absorbing materials (rubber) used in the system may generate gases that may cause the deterioration of the polarizer laminated on LCD's panel or internal parts of the LCD module. Prior confirmation is required.

6) GAS GENERATED FROM CASING /PACKAGING MATERIAL FOR A SET

Some materials used for packaging (for which sulfuric acid is used in the recycling process) generate gases that may cause the deterioration of the polarizer laminated on LCD's panel or internal parts of the LCD module. Prior confirmation is required.

2-2. DESIGNING POWER SUPPLIES AND INPUT SIGNALS TO LCD MODULE

1) SEQUENCE OF POWER SUPPLIES AND INPUT SIGNALS

Refer to "3 Recommended Operating Conditions for Driving LCD" described in this Specification. If the recommended operating conditions are not followed, it may cause miss-operation of the panel.

In addition, refer to individual specifications for unused terminals.

2) IMAGE STICKING IN A DISPLAY

Design the system not to display the same pattern for a long time.

Continuing the same pattern display for a long time or inputting the signals besides recommendation may cause the phenomenon "image sticking" which remains vaguely after changing patterns.

2-3 DESIGNING FOR BETTER VISIBILITY

1) PANEL ANGLE

Visibility of LCD module deeply depends on the viewing directions. The position and the angle of LCD module in the system should be designed so that the best visibility can be obtained at the actual usage.

2) WINDOW OPENING

Dimensions of window opening of the system's enclosure should be designed as smaller than "Viewing Area" and larger than "Active Area" specified in individual specification in order to prevent that a part of screen is interrupted by the enclosure and disappears.

3) PROTECTIVE COVER/ ULTRA-VIOLET CUT FILTER

In case of severe environmental condition like outdoor usage, a proper transparent protective cover (lens) over LCD module is recommended, to prevent scratches, invasion of dust and water, etc, between the system housing and the LCD module.

It is recommended to apply an ultra-violet filter (less than 390nm cut) onto the LCD module, for outdoor operation.

Strong ultra-violet radiation may damage the panel. However, in that case, transmittance-luminance will decrease. Careful selection of material is required.

Don't expose any parts, except the viewing area, into the direct sunlight, otherwise deterioration may occur.

For Installation in Assembly

3-1 CARRYING

Hold the side of the LCD module when carrying with hand. Holding FPC may cause failures, in the worst case, it may cause smoke or burn.

Protection (e.g. gloves) for fingers and hands is recommended, to avoid injury by broken glass.

3-2 CAUTIONS TO PREVENT FROM ELECTROSTATIC DESTRUCTION UNDER ASSEMBLY WORK

Consider the following to prevent the static electricity from generating under assembly work. High-voltage static electricity discharge destroys the circuit inside the module and it may cause failures.

1) HUMIDITY

Maintain a work place in the range of 50 to 70% of relative humidity, to prevent generation and discharge of static electricity.

2) GROUNDING

2-1) Cover the floor of a work area and a work desk with a conductive mat, and ground them, through resistance with range of 0.5 MΩ to 1MΩ, to prevent discharge all at once.

2-2) Workers must wear a grounded wrist band.

2-3) Ground all metallic tools, jigs and equipment, such as a soldering iron and a screw driver, jigs, conveyors, or metallic work benches, which are to be used for assembly work.

3) IONIZER

Using ionizer (an antistatic blower) is recommended at working area in order to reduce electro-static voltage.

4) REMOVING PROTECTION FILM

The protection film is stuck on an LCD panel before its shipment to prevent dust or scratch on the panel during transportation, assembly work or otherwise. Remove a protection film on an LCD panel near the last process of an assembly to prevent dust and scratch on the panel.

However, remove the film in advance in case of a set attached a module is inserted into high temperature chamber for aging etc. If it is left without removing the film, it may cause irregular polarizer surface.

When removing the protection film, peel off the tag carefully and slowly, spending more than 1 second.

In peeling off the protection film, blow the film using ionizer to eliminating ESD from the film.

Removal which does not comply with the above procedure may generate ESD and damage electric circuit of a LCD module.

5) Do not touch bare metal portions of examination /inspection equipment. It causes to discharge electric charge of an object or a human body.

6) Do not touch the mounting parts on PCB LCD module, circuit patterns or FPC terminals with worker's hand or conductive tools.

3-3 DUST AND STAIN PREVENTION

1) WORKING AREA

Handle the LCD module in the room with out metallic dust. Especially when metallic dust adheres to the LCD module, an internal electric circuit makes short-circuited and it may cause failures.

2) FINGER PRINT

Handle the LCD module fingerstalls or soft and dust-free gloves that do not produce dust when performing incoming inspection of modules or assembling sets. Handling them with bare hand may damage module display quality.

***3) WIPING OFF DUST ON THE PANEL**

When LCD panel becomes dirty, wipe the panel surface off softly with absorbent cotton or another soft cloth.

If necessary, breathe upon the panel surface and then wipe off immediately and softly again.

Be careful not to spill organic solvents into the inside of LCD module. The organic solvents may damage driver IC and PCB area used inside module.

The polarizer laminated to LCD panel and adhesives may be damaged by organic the solvents, so do not use any organic solvents for wiping off LCD panel.

Gently wipe away surface dirt with a soft cloth containing ethanol. Don't use anything other than ethanol or water, as it may cause damage

4) PROTECTION AGAINST ADHESION OF ADHESIVE OR GREASE ON A DISPLAY

Be careful not to attach adhesive or grease etc. used for the assembly of a set on a LCD module display. It is difficult to remove them without damaging display quality.

***5) WATER DROP ON A DISPLAY**

Do not leave water drop attached on a display. When water drop etc. is attached, wipe it off with absorbent cotton or soft cloth etc. immediately. If it is left without wiped off, a display discolors, or it causes spots. Moreover, moisture's infiltration into an inside causes failures.

Avoid the dewing or water condensation.

The indication sides discolor and stain upon contact with water. And, damage may occur if water penetrates the inside.

6) HANDLING IN THE CORROSIVE ATMOSPHERE

Do not blow gas or do not use a LCD module besides the normal atmosphere. It may cause failures.

3-4 BENDING / TWISTING OF LCD MODULE UNDER ASSEMBLY**1) INSTALLING LCD MODULE TO THE ENCLOSURE**

Do not bend or twist LCD module even momentary when LCD module is installed into an enclosure of the system.

Bending or twisting LCD module may cause its damages.

2) FOR PREVENTION OF CATCHING FPC

Be careful not to let interface FPC etc. caught in a set enclosure and a LCD module while assembling a LCD module in a set.

Assembling with FPC caught in may cause bending, twist of a LCD module, or damage and failure of FPC.

3-5. MECHANICAL FORCES***1) STRONG MECHANICAL SHOCK**

Avoid strong mechanical shock, such as dropping the LCD from the work bench, or knocking it against a hard object.

These may cause the glass panel to crack, or cause other miss-operation.

***2) EXCESSIVE FORCE**

Avoid applying excessive force, like pushing the surface of LCD panel. This may cause scratches or breakage of the panel, or a failure of the module

***3) PREVENTION FOR SCRATCHES ON A DISPLAY**

Be careful not to touch hard things, such as a tool etc., press a module display with them or rub a module display with them.

Moreover, be careful not to put heavy things, such as a tool etc., or pile up LCD module displays.

As polarizing plates used for a display is easy to be damaged, it may cause scratches, trace, or breakage of the plate.

***4) HOW TO CONNECTION OF FPC**

Be careful not to apply a strong external force to FPC of a LCD module when inserting or removing FPC into a connector of a set. A strong external force may damage connection of FPC.

Insert them correctly so that interface FPC and a connector of a set are not inserted oblique or half, and be sure to check them. When inputting signals etc. without inserting them correctly, it may cause failures of circuit parts.

5) HANDLING FPC

Be careful not to pull or damage the FPC, to avoid mechanical damage in FPC and connection part of FPC and cell. In addition, be careful not to be added strong external force to FPC. When the external strong force is added to FPC, it may cause module failures due to breakage of mounting parts and circuit on FPC.

3-6. OPERATION

Be sure that the following caution should be taken under assembly and inspection of the system.

1) POWER SUPPLY WHILE WORKING/ASSEMBLING

Be sure to turn off the power of a set while working. Pulling out and inserting a LCD module connector with the power of a set turned on may damage a LCD module electric circuit. When turning on the power in a testing process, an inspection process etc., use the power supply and input signals for a drive unit which satisfy the power supply sequence described in this Specification.

For Transportation and Storage**1) STORAGE UNDER HIGH TEMPERATURE AND HIGH HUMIDITY**

Be careful not to store a LCD module for a long time (about one month or more) under the condition of high temperature and high humidity (35°C or more, 70% or more of relative humidity). This may deteriorate display quality.

When it is necessary to store unavoidably for a long term, in the state of packing by our company (before opening), store it within the range of 0°C to 35°C and in the dry place of 70% or less of relative humidity.

2) SOLIDIFICATION ON THE LIQUID CRYSTAL IN CRYOGENIC CONDITION

Since a temperature lower than a rated storage temperature described in this Specification may damage a LCD module liquid-crystal-display panel due to the solidification or contraction etc. On liquid crystal, be careful not to leave it in such a place.

3) BE CAUTIOUS OF STRONG ULTRAVIOLET

Be careful not to expose a LCD module to the sunlight or a fluorescent light directly to protect a LCD module from strong ultraviolet, when storing modules for a long term.

4) CLEANLINESS

Keep the LCD module in clean place, because any dust, hard particle may damage the polarizer, or dust invades the inside of the LCD module.

***5) CONDENSATION OF WATER**

The modules should be stored under a condition where no condensation of water is allowed. It may cause miss-operation or defects. Be especially careful not to make a module work under the condition that condensation of water appears.

6) REPACKAGING

Use an original packing box and original packing material, and pack this LCD module with the same original method and same kind of desiccant, when transporting and storing it again after opening it by customer.

7) NOTES FOR THE ADOPTION OF NEW PACKING MATERIAL

Since some of the cartons for packing or the rubber parts etc. generate corrosive gas, confirm a reliability check in the set assembling state or the packing state before the adoption.

- Table of Contents -

	Sheet
Revision History	1
1. Scope of Application	10
2. Product Specifications	10
2.1 General Specificaitons.....	10
2.2 Absolute Maximum Ratings.....	11
2.3 Mechanical Specifications	12
2.3.1 Outline Drawing.....	12
2.4 Electrical Specifications.....	13
2.4.1 Block Diagram.....	13
2.4.2 Connector Pin Assignment	14
3. Recommended Operating Conditions for Driving LCD	15
3.1 Command sequence	16
3.1.1 Status Flow.....	16
3.1.2 Sequence	16
3.1.3 Power Supply Sequence.....	19
4. Product Specifications	20
4.1 Mechanical Test	20
4.1.1 External View	20
4.1.2 Outside Dimensions	21
4.1.3 Markings.....	21
4.2 Electrical Characteristic Test.....	21
4.2.1 Common Conditions for Inspections.....	21
4.2.2 Consumption Current.....	21
4.3 Optical Characteristics.....	22
4.3.1 Common Conditions for Inspections.....	22
4.3.2 Optical Characteristic Specifications	22
4.4 Display Quality Specifications	23
4.4.1 Test Conditions	23
4.4.2 Externals and Display Specification.....	23
4.5 Quality Level of External & Display screen	24
4.6 Reliability Test	24
4.6.1 Electrical/Mechanical/Envitonmental Test	24
4.6.2 Judgment.....	24
5. Package	25
6. Test Method	26
6.1 Optical Test Method	26
6.2 Display Quality Level Test Procedures	27
7. Others	27
7.1 Applicable Standard	27
7.2 Consultations on Doubtful and Unsettled Matters.....	27

1 Scope

This specification shall be applicable to TFT-LCD module LT070ME05000, designed for cellular phone.

2 Product Specifications

2.1 General Specifications

Item	Specifications	Remark
Display Mode	Dual Compatible Domain Color transmissive Type (16,777,216colors), Normally Black	
Driving Method	TFT active matrix, Low-temperature poly-silicon	
Input Signals	MIPI-DSI	
Outside Dimensions	98.7(W) x 160.8(H) x 1.975(D) (mm) (typ.)	1)
Active area	94.5(W) x 151.2(H) (mm)	
Number of Pixels	1200 (W) x 1920 (H)	2)
Pixel Pitch	0.07875 (W) x 0.07875 (H) (mm)	2)
Pixel arrangement	RGB Vertical stripe	
Weight	66g@typ.	

Note 1) Without FPC.

Note 2) Refer to the below.

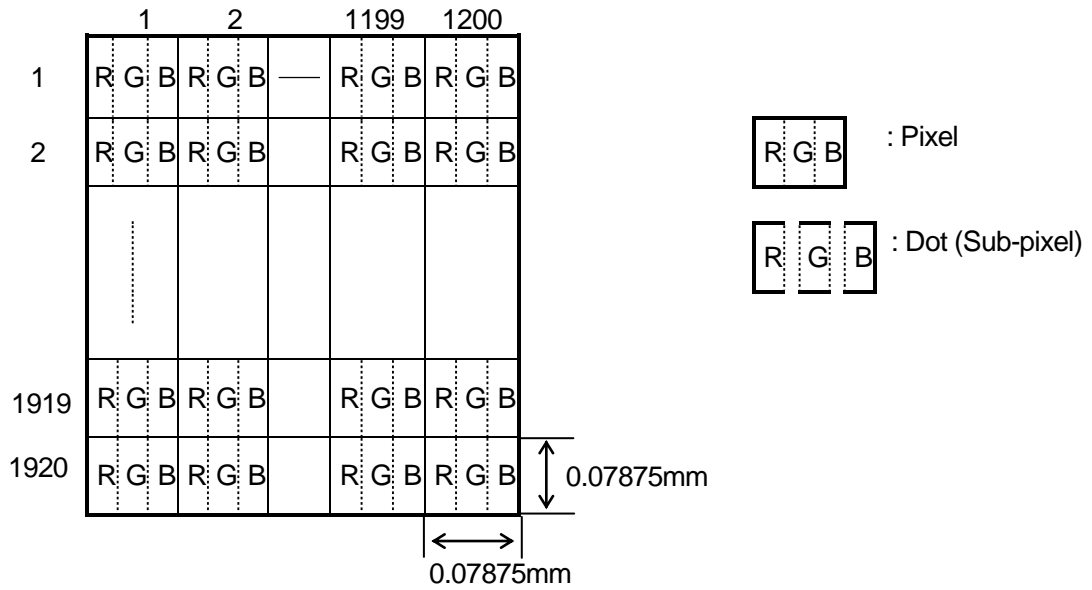

2.2 Absolute Maximum Ratings

Item ¹⁾	Symbol	Min.	Max.	Unit	Remark
Power supply voltage (Analog)	VDD-GND	-0.3	6.0	V	
	VDDp-GND	-0.3	6.0	V	
Power supply voltage (Logic)	IOVCC	-0.3	4.6	V	
Input signal voltage (RES)	V _I	-0.3	IOVCC+0.3	V	XRES
Input signal voltage (DSI)	V _{I(DSI)}	-0.3	1.8	V	
Input signal voltage (LED)	V _{I(LED)}	-0.3	6.0	V	LED_EN
Input signal voltage (PWR)	V _{I(PWR)}	-0.3	5.5	V	DCDC_EN
Operating temperature	T _{OP}	-10	+60	°C	²⁾
Storage temperature	T _{STG}	-30	+70	°C	²⁾

Note 1) The absolute maximum ratings are the values that must not be exceeded at any time for this product. It is not allowed for any of these ratings to be exceeded. Should a module be used with any of the absolute maximum ratings exceeded, the characteristics of the module may not be recovered, or in an extreme case, the module may be permanently destroyed.

Therefore, when designing a system incorporating the module, make sure that adequate attentions be paid to the variations in the supply voltages, the characteristics of parts that are connected, surges in the input and output lines, and the ambient temperatures.

Note 2) Should be no condensation.

2.4.2 Connector Pin Assignment

Mating Connector:

Connector on FPC :FH35C-31S-0.3HW(50) (HIROSE)

Connector on Board : --

No	PIN Name	Contents	In/Out
1	VDD	LED power supply (3-5V)	Input
2	VDD	LED power supply (3-5V)	Input
3	VDD	LED power supply (3-5V)	Input
4	VDD	LED power supply (3-5V)	Input
5	GND		-
6	LED_EN	LED backlight enable, High active	Input
7	N.C.		-
8	GND		-
9	MIPI_3N	MIPI data 3 negative signal	Input
10	MIPI_3P	MIPI data 3 positive signal	Input
11	GND		-
12	MIPI_0N	MIPI data 0 negative signal	In/Output
13	MIPI_0P	MIPI data 0 positive signal	In/Output
14	GND		-
15	MIPI_CLKN	MIPI CLK negative signal	Input
16	MIPI_CLKP	MIPI CLK positive signal	Input
17	GND		-
18	MIPI_1N	MIPI data 1 negative signal	Input
19	MIPI_1P	MIPI data 1 positive signal	Input
20	GND		-
21	MIPI_2N	MIPI data 2 negative signal	Input
22	MIPI_2P	MIPI data 2 positive signal	Input
23	GND		-
24	XRES	Reset, Low active	Input
25	TE		Output
26	VDDp	Power IC supply (3-5V)	Input
27	VDDp	Power IC supply (3-5V)	Input
28	GND		-
29	GND		-
30	DCDC_EN	Power IC supply enable, High active	Input
31	IOVCC	Power supply for LCM (1.8 +/- 0.1V)	Input

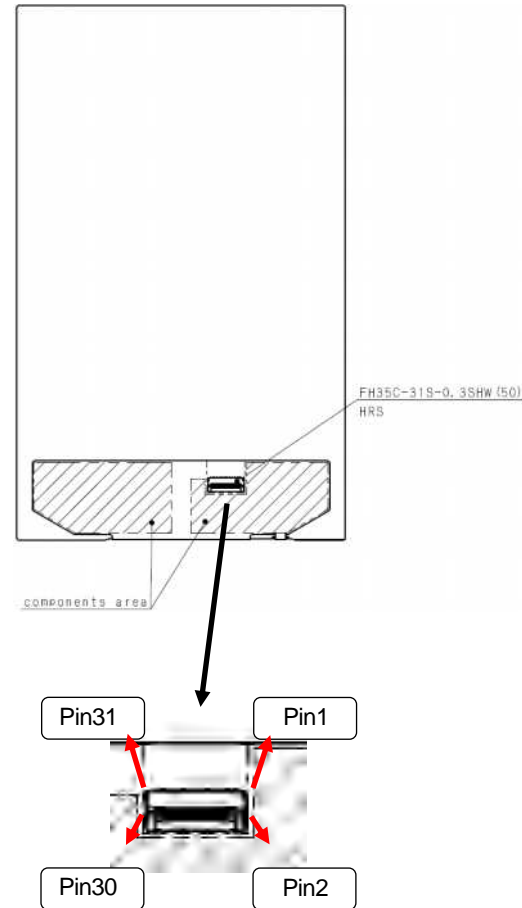

3 Recommended Operating Conditions for Driving LCD

(Ta=25°C)

Item		Symbol	Min.	Typ.	Max.	Unit	Remark
Power supply voltage for Analog		VDD	3.0	-	5.0	V	
		VDDp	3.0	-	5.0	V	
Power supply voltage for Logic		IOVCC	1.70	1.80	1.90	V	
Input signal voltage (RES)		V _{IL}	0	-	0.3*IOVCC	V	XRES
		V _{IH}	0.7*IOVCC	-	IOVCC	V	
Output signal voltage (TE)		V _{OL}	0	-	0.2*IOVCC	V	TE
		V _{OH}	0.8*IOVCC	-	IOVCC	V	
Input signal voltage (DSI)	Low level	V _{IL(DSI)}	-50	-	550	mV	Low Power Receiver
	High level	V _{IH(DSI)}	880	-	1350	mV	
	Input voltage	V _{CMRX}	70	-	330	mV	High Speed Receiver
	Differential input low threshold	V _{IDTL}	-70	-	-	mV	
	Differential input high threshold	V _{IDTH}	-	-	70	mV	
Input signal voltage (LED)		V _{IL(PWR)}	1.5	-	VDD	V	LED_EN
		V _{IH(PWR)}	0	-	0.5	V	
Input signal voltage (PWR)		V _{IL(LED)}	1.4	-	VDDp	V	DCDC_EN
		V _{IH(LED)}	0	-	0.4	V	

Note 1) The recommended operating conditions refers to a range in which operation of this product is guaranteed. Should this range is exceeded, the operation cannot be guaranteed even if the values may be within the absolute maximum ratings. Accordingly, please make sure that the module is used within this range.

3.1 Command sequence

3.1.1 Status Flow

(1200RGBx1920, R69429, MIPI 4lane)

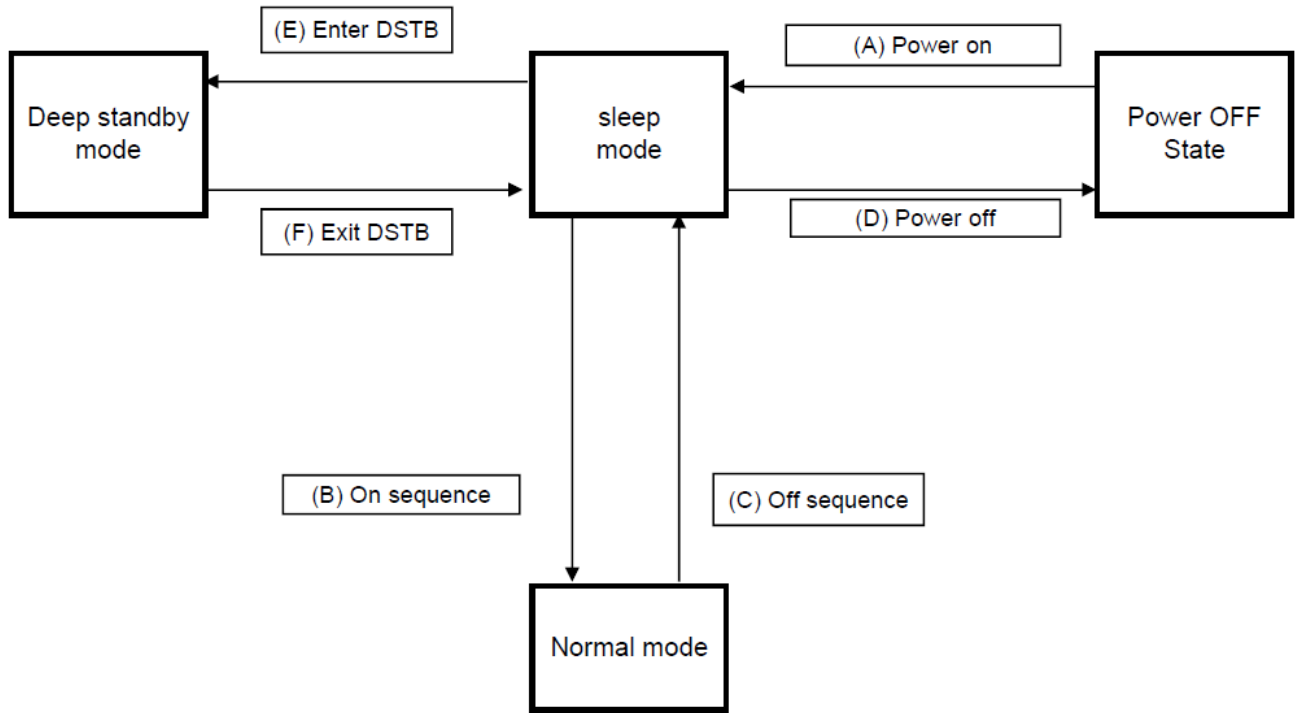

3.1.2 Sequence

(A) Power on

sequence	DataTyp (hex)	index (hex)	parameters # (hex)	description	comment
POWER OFF STATE					
↓					
PWR supply on				IOVcc on	DSI input should be at GND level while IOVcc off.
wait 5ms					
PWR supply on				Vddp(VSP,VSN PWR) on	
wait 3ms					
DCDC_EN L->H				DCDC_EN L->H (VSP,VSN on)	
wait 20ms					
RESET L->H				RESET L->H	
wait 10ms					
DCDC_EN H->L				DCDC_EN H->L (VSP,VSN off)	(*1)Can skip "DCDC_EN H->L" in case of going to normal mode without staying sleep status.
wait 20ms					
↓					
SLEEP MODE					

(B) On sequence

sequence	Data Type (hex)	index (hex)	parameters # (hex)	description	comment
SLEEP MODE					
↓					
DCDC_EN L->H				DCDC_EN L->H (VSP,VSN on)	
wait 20ms					
command	05	01	- -	soft reset	
wait 5ms					
command	23	B0	1 00	MCAP	
command	29	B3	1 04	Interface setting	
			2 08		
			3 00		
			4 22		
			5 00		
command	29	B4	1 0C	Interface ID setting	
command	29	B6	1 3A	DSI control	
			2 D3		
command	15	51	1 E6	write display brightness	
command	15	53	1 2C	write control display	
command	15	3A	1 77	set pixel format	
command	39	2A	1 00	set column address	
			2 00		
			3 04		
			4 AF		
command	39	2B	1 00	set page address	
			2 00		
			3 07		
			4 7F		
send image	39	2C/3C		write memory / write memory continue	
command	05	11	- -	exit sleep mode	
wait 120ms					
command	05	29	- -	set display on	
wait min 0ms					
LED_EN L->H				LED_EN L->H	
↓					
NORMAL MODE					

(C) Off sequence

sequence	Data Type (hex)	index (hex)	parameters # (hex)	description	comment
NORMAL MODE					
↓					
command	05	28	- -	set display off	
wait 20ms					
command	05	10	- -	enter sleep mode	
wait 80ms					
DCDC_EN H->L				DCDC_EN H->L (VSP,VSN off)	
wait 20ms					
↓					
SLEEP MODE					

(D) Power Off

sequence	DataTyp (hex)	index (hex)	parameters # (hex)	description	comment
SLEEP MODE					
↓					
RESET H->L					
PWR supply off				IOVcc off	DSI input should be at GND level while IOVcc off.
↓					
POWER OFF STATE					

(E) Enter DSTB

sequence	DataTyp (hex)	index (hex)	parameters # (hex)	description	comment
SLEEP MODE					
↓					
command	23	B0	1 00	MCAP	
command	23	B1	1 01	DSTB=1	
↓					
DSTB MODE					

(F) Exit DSTB

sequence	DataTyp (hex)	index (hex)	parameters # (hex)	description	comment
DSTB MODE					
↓					
RESET H->L					
wait 10ms					
PWR supply on				Vddp(VSP,VSN PWR) on	
wait 3ms					
DCDC_EN L->H				DCDC_EN L->H (VSP,VSN on)	
wait 20ms					
RESET L->H				RESET L->H	
wait 10ms					
DCDC_EN H->L				DCDC_EN H->L (VSP,VSN off)	(*1)Can skip "DCDC_EN H->L" in case of going to normal mode without staying sleep status.
wait 20ms					
↓					
SLEEP MODE					

3.1.3 Power Supply Sequence

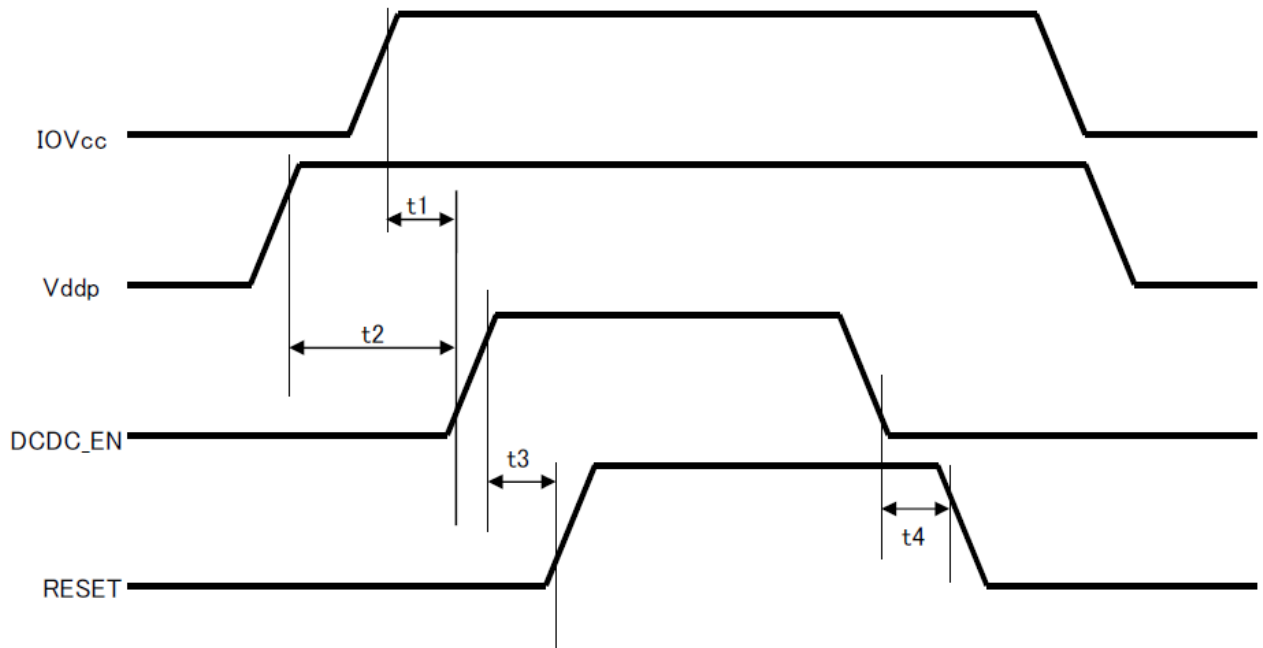

Item	Symbol	Unit	Min	Typ	Max
IOVCC on to DCDC_EN on time	t1	ms	1	3	-
VDDP on to DCDC_EN on time	t2	ms	1	3	-
DCDC_EN on to REST on time	t3	ms	12	20	-
DCDC_EN off to REST off time	t4	ms	15	20	-

4 Product Specifications

4.1 Mechanical Test

4.1.1 External View

(1) Test Conditions

Environment (Luminance)	: 500+/-50lx (Fluorescent light)
Temperature	: 25±5°C
Humidity	: 60±20% (RH)
Distance between eyes and the module	: 300 +/-50 mm
Viewing cone angle	: 90° +/- 30°

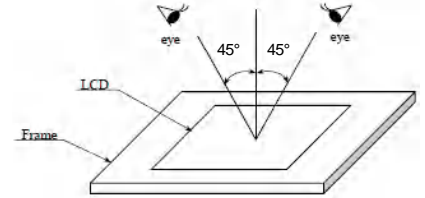

(2) Standard for External View

Item	Criteria		
LCD panel 1),2)	Any defect in the active display area (Granular, Linear, CF Scratch, and glue) satisfy the following condition. 1)2)3)4)5)6)		
	Item		Allowed Number
Foreign Particles Circular [mm] D: Maximum diameter	D≤0.1		disregard
	0.1<D≤0.25		3
	0.25<D		0
Foreign Particles Liner [mm] W1/W2: Width, L: Length	W≤0.03	L<3.0	disregard
	0.03<W≤0.08	L<3.0	3
	0.08<W	-	0
	-	3.0<L	0
Scratch on Polarizer Circular [mm] D: Maximum diameter	D≤0.15		disregard
	0.15<D≤0.25		3
	0.25<D		0
Bubble in Polarizer Circular [mm] D: Maximum diameter	D≤0.1		disregard
	0.1<D≤0.3		3
	0.3<D		0
Dent on Polarizer Circular [mm] D: Maximum diameter	D≤0.1		disregard
	0.1<D≤0.3		2
	0.3<D		0
Linear Scratch on Polarizer / Glass Liner [mm] W: Width, L: Length	W≤0.01	-	Disregard
	0.01<W≤0.03	L≤10.0	3
	0.03<W≤0.08	L≤3.0	3
	0.01<W≤0.03	10.0<L	0
	0.03<W≤0.08	3.0<L	0
	0.08<W	-	0

- Note 1) Bright defect should be judged by bright dots spec. in 4.4 Display Quality Specifications
 2) Wave of the surface on the polarizer should not be counted.
 3) The inspection condition of polarizer surface is w/ protection sheet.
 4) Light source is fluorescence Lamp.
 5) If there are some limited samples signed by customer, it is judged by them.
 6) The foreign material (including sticking glue) that we cannot remove between protection film and polarizer follows foreign particles circular or foreign particles liner.

4.1.2 Outside Dimensions

Outside dimensions should satisfy the values indicated on 2.3.1 Outline Drawing.

4.1.3 Markings

(1) Product Label

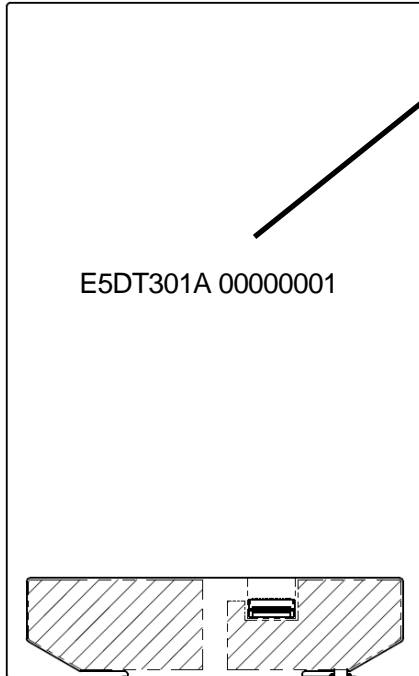

E 5 D T 3 0 1 A 0 0 0 0 0 0 0 1

1) 2) 3) 4) 5) 6) 7) 8)

- 1) Production Number : LT070ME05000
- 2) Panel Factory code : D (G5.5 Panel), J (G6 Panel)
- 3) Module factory code : T(TOC), W(Wistron)
- 4) Production Year ('13) : 3
- 5) Production weeks (cumulative) : 01
- 6) Revision Number : A(Original: 180Kohms),
B(Resistor changing to 220Kohms)
- Space
- 7) Division of SPEC : 0 (Customer Spec)
: A (JDI Spec)

4.2 Electric Characteristic Test

4.2.1 Common conditions for Inspections

- Ambient temperature : 25°C ± 5°C
- Ambient humidity : 60 ± 20%RH
- Supply voltage : IOVCC=1.8V, VDD=3.0V, VDDp=3.0V

4.2.2 Consumption Current

Item	Symbol	Min.	Typ.	Max.	Unit	Remark
Panel Consumption	I _{IOVCC}	-	(11.0)	(13.0)	mA	White Pattern
	I _{VDDp}	-	(37.0)	(54.0)	mA	
B/L Consumption	I _{VDD}	-	(450)	(500)	mA	I _F =20mA/p, Duty:90%

4.3 Optical Characteristics

4.3.1 Common Conditions for Inspections

Ambient temperature : 25°C ± 5°C

The other conditions are the same as those under 4.2.1 Common Verification Conditions.

For Test Procedures, see 6.1 Optical Test Procedures.

4.3.2 Optical Specifications

Item	Symbol	Conditions	Specifications			Unit	Remark	
			Min.	Typ.	Max.			
Contrast ratio	CR	Display: White/Black	700	1100	-	-		
Viewing Angle	θ	CR>10	$\phi = 180^\circ$	80	-	-	deg	1) 2)
			$\phi = 0^\circ$	80	-	-	deg	
			$\phi = -90^\circ$	80	-	-	deg	
			$\phi = +90^\circ$	80	-	-	deg	
Luminance	L	Displayed White	350	450	-	cd/m ²	I _F =18mA/p	
Luminance uniformity	L _{unf}	Displayed White	80	-	-	%		
Displayed Color	X _R	Displayed red	0.60	0.64	0.68	-		
	Y _R		0.29	0.33	0.37	-		
	X _G	Displayed Green	0.27	0.31	0.34	-		
	Y _G		0.57	0.61	0.64	-		
	X _B	Displayed Blue	0.11	0.15	0.19	-		
	Y _B		0.01	0.05	0.09	-		
	X _W	Displayed White	0.28	0.31	0.34	-		
	Y _W		0.30	0.33	0.36	-		
NTSC Ratio			66.5	71.5	-	%		
Gamma			-	2.2	-	-		
Cross Talk			-	-	4	%	3)	

Note 1) The definition of the Viewing Angle is as figure.

Note 2) The definition of the Viewing cone is as figure 2. Refer to Limit sample to judgment is evaluated by the pattern form customer.

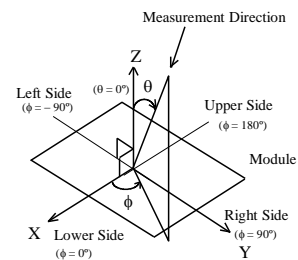

4.4 Display Quality Specifications

4.4.1 Test Conditions

- Display surface luminance : 200 +/- 50 lx (Fluorescent light)
 - Test area : Active area
 - Distance between eyes and the module : 300 +/- 50 mm
 - Viewing core angle : 90° +/- 30°
 - Driving condition : Refer to 4.2.1 Standard value of timing specification
- Refer to 6.2 Display Quality Level Test Procedures.

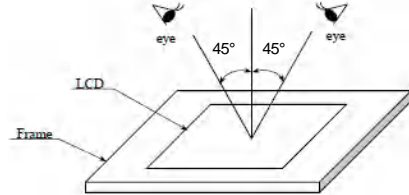

4.4.2 Display Specifications

(1) Defects in Display

Item	Criteria														
Dot defects 1) 2)3)	Definition bright and dark dots (only valid for display ON)														
	External defects that look like bright/dark dot will be counted as an internal defect.														
	<table border="1"> <thead> <tr> <th colspan="2">Type of defect</th> <th>Allowed number</th> </tr> </thead> <tbody> <tr> <td rowspan="3">Bright dots</td> <td>Not appearance less than or equal to pseudo dot or not appearance under ND20%</td> <td>Disregard</td> </tr> <tr> <td>Not appearance under ND filter 6% (Distance: more than 5mm)</td> <td>10</td> </tr> <tr> <td>Appearance under ND filter 6%</td> <td>2</td> </tr> <tr> <td>Dark Dot</td> <td>Adjacent dots: 0.1<D≤0.25mm, D≤0.1mm: Disregard (Distance: more than 5mm)</td> <td>6</td> </tr> </tbody> </table>		Type of defect		Allowed number	Bright dots	Not appearance less than or equal to pseudo dot or not appearance under ND20%	Disregard	Not appearance under ND filter 6% (Distance: more than 5mm)	10	Appearance under ND filter 6%	2	Dark Dot	Adjacent dots: 0.1<D≤0.25mm, D≤0.1mm: Disregard (Distance: more than 5mm)	6
	Type of defect		Allowed number												
	Bright dots	Not appearance less than or equal to pseudo dot or not appearance under ND20%	Disregard												
		Not appearance under ND filter 6% (Distance: more than 5mm)	10												
		Appearance under ND filter 6%	2												
	Dark Dot	Adjacent dots: 0.1<D≤0.25mm, D≤0.1mm: Disregard (Distance: more than 5mm)	6												
	Any dark defect (Granular, Linear) in the active display area satisfy the following condition.														
	<table border="1"> <thead> <tr> <th>Item</th> <th>Allowed Number</th> </tr> </thead> <tbody> <tr> <td rowspan="3">Foreign Particles Circular [mm] D: Maximum diameter</td> <td>D≤0.1 disregard</td> </tr> <tr> <td>0.1<D≤0.25 3</td> </tr> <tr> <td>0.25<D 0</td> </tr> <tr> <td rowspan="4">Foreign Particles Liner [mm] W1/W2: Width, L: Length</td> <td>W≤0.03 L<3.0 Disregard</td> </tr> <tr> <td>0.03<W≤0.08 L≤3.0 3</td> </tr> <tr> <td>0.08<W - 0</td> </tr> <tr> <td>- 3.0<L 0</td> </tr> </tbody> </table>		Item	Allowed Number	Foreign Particles Circular [mm] D: Maximum diameter	D≤0.1 disregard	0.1<D≤0.25 3	0.25<D 0	Foreign Particles Liner [mm] W1/W2: Width, L: Length	W≤0.03 L<3.0 Disregard	0.03<W≤0.08 L≤3.0 3	0.08<W - 0	- 3.0<L 0		
Item	Allowed Number														
Foreign Particles Circular [mm] D: Maximum diameter	D≤0.1 disregard														
	0.1<D≤0.25 3														
	0.25<D 0														
Foreign Particles Liner [mm] W1/W2: Width, L: Length	W≤0.03 L<3.0 Disregard														
	0.03<W≤0.08 L≤3.0 3														
	0.08<W - 0														
	- 3.0<L 0														

Note 1) Defects of both color filter and black matrix are counted as bright or dark defects.
Inspection area should be within the active area.

Note 2) Bright dots includes a bright spot (sub-pixel) or a foreign material (D≤0.15mm).

Note 3) If there is some limited samples signed by customer, it is judged by them,

4.5 Quality Level of External & Display screen

Item	Criteria	Remarks
Abnormal display	No function or not to get normal pattern	Operating
Line defect	Shall not be observed.	Operating
Moire fringes	No conspicuous streak shall exist.	Operating
Stain	Shall not be conspicuous.	Punctuate irregularity of luminance.
Ununiformity	Shall not be conspicuous.	Irregularity of luminance and color, larger in size than stain.
Streak	Shall not be conspicuous	Linear irregularity of luminance (including vertical, horizontal, and diagonal streaks).

4.6 Reliability Test

4.6.1 Electrical / Mechanical / Environmental Test

After the tests as listed below have been performed, this module shall satisfy the criteria as listed under 4.5.2. However, only a single item of these tests shall be executed on a single module. A number of test items shall not be executed on a single module.

Test Item	Test Conditions	Remark
High Temperature Operation	60°C, 240 hours	Operating
Low Temperature Operation	-10°C, 240 hours	Operating
High Temperature and High Humidity Operation	40°C, 95%, 240 hours	Operating
High Temperature Storage	70°C, 240 hours	Storage
Low Temperature Storage	-30°C, 240 hours	Storage
High Temperature and High Humidity Storage	60°C, 90%, 240 hours	Storage
Thermal Shock	-30(30min) ⇔ 70(30min), 27 cycles	Storage
ESD Test	Air +/-10kV, Contact +/-6kV, Human body model (150pF, 330ohms), center pane surfacel and center rear bezel surface	No operating

Note 1) The test shall be executed under a condition where no condensation is formed.

Note 2) After the test, the module should be left at normal temperatures (15 - 35°C). Then the module should be inspected for normal operation.

Note 3) Should be no condensation.

Note 4) Except for the degradation of polarizer.

4.6.2 Judgment

- (1) There shall be no abnormality in the functions and the display.
- (2) Appearance and display quality should not have distinguished degradation.
- (3) For package tests, remarkable dust generation is not allowed.

5 Packaging

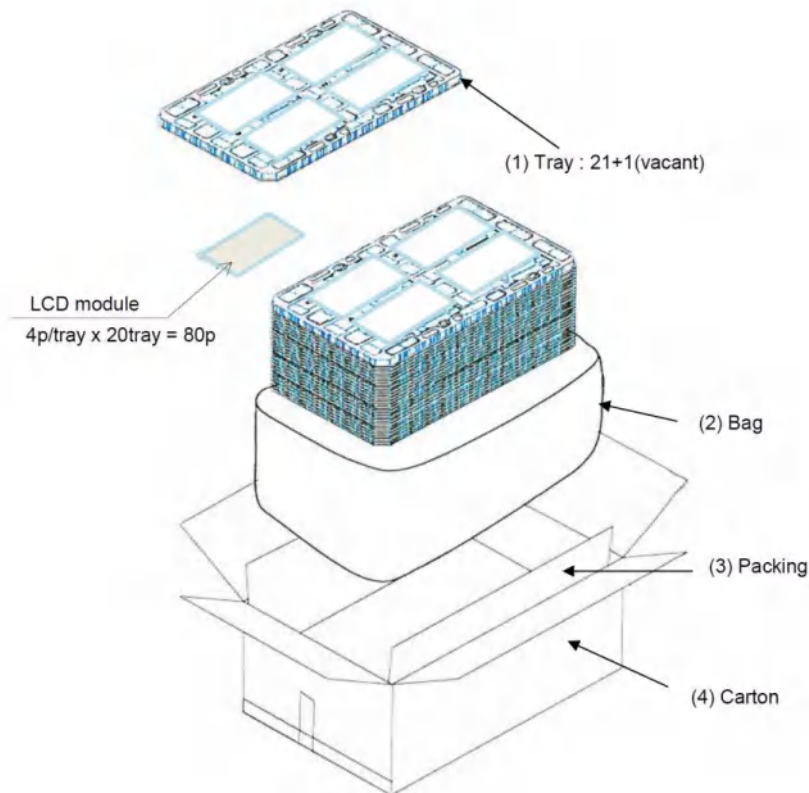

(5) Plastic adhesive tape

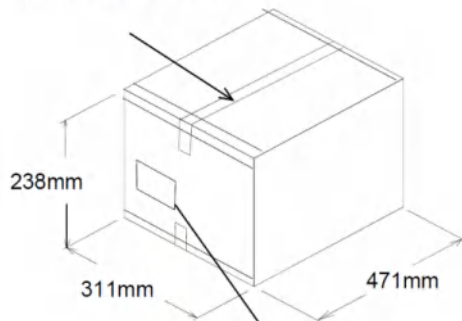

1	LT070ME05000
2	80p
3	T.B.D *****
MADE IN CHINA	

- | |
|---------------------|
| 1. JDI Product Name |
| 2. Quantity |
| 3. JDI Product Code |

6 Test Method

6.6 Optical Test Method

- Environment : Inside a dark room
- Measuring Instrument : Used as shown below
- Measurement point : Center of Active area unless otherwise specified
- Direction of measurement : Vertical direction at Active area unless otherwise specified

Measurement System

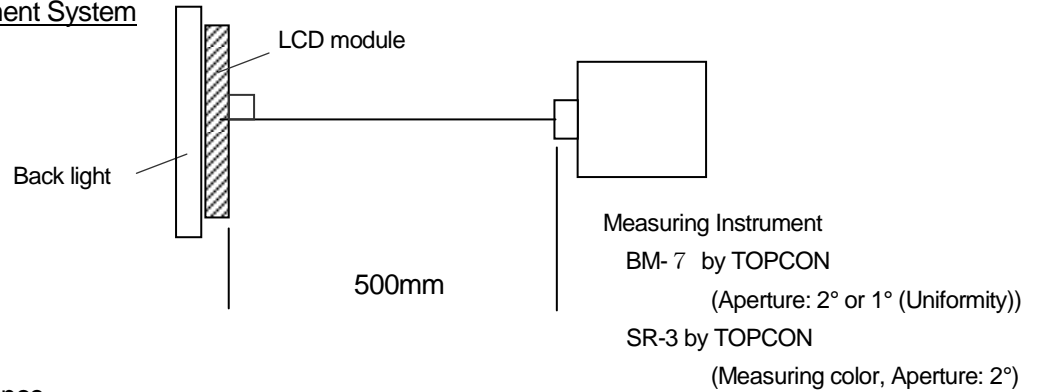

(1) Luminance

Measure the luminance when white is displayed (gradation level L255) , and measure the Luminance.

(2) Contrast Ratio

Measure the luminance when black is displayed (gradation level L0), and the luminance when white is displayed (gradation level L255), and then contrast *CR* should be obtained from the next expression:

$$CR = L_{255} / L_0$$

(3) Viewing Angle

Measure the contrast ratio by the direction specified by the conditions under item 4.3.2.

(4) Luminance uniformity

Measure the luminance when white is displayed (gradation level L255), and so obtain luminance uniformity L_{unf} in the next expression.

$$L_{unf} = (\text{Minimum luminance in the 9 point}) / (\text{Maximum luminance in the 9 point}) \times 100$$

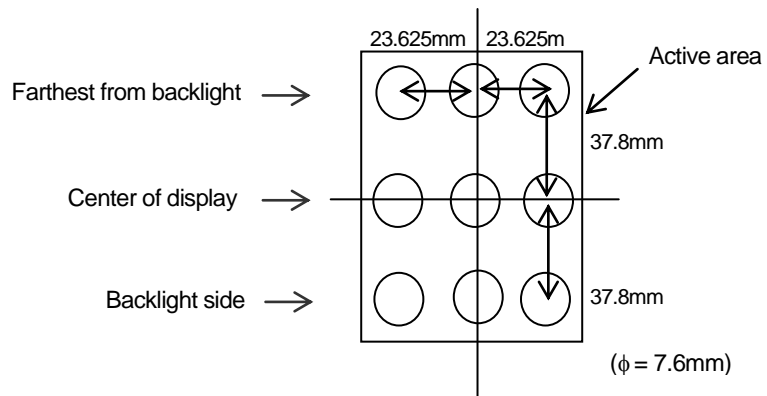

(5) Displayed Color

Measure the displayed color of white raster (white: gradation level L255), red raster (red: gradation level L255), green raster (green: gradation level L255), blue raster (blue: gradation level L255), and measure each of the chromaticity coordinates: x_W , y_W , x_R , y_R , x_G , y_G , x_B , and y_B .

6.7 Display Quality Level Test Procedures

Under 4.4.1 Common Conditions for Inspections, visually observe the active display area. Depending on the size of a defect, use a spot gauge and a magnifying glass. Judgments shall be made in accordance with 4.4.2 Display Quality Level Specifications.

7 Others

7.6 Applicable Standard

No warranty that satisfies the standards as shown below will be offered from our company, with the LCD module incorporated into a system.

In addition, no warranty that satisfies the standards as shown below will be offered from our company for a stand-alone unit of the LCD module.

Should compliance to the standards as shown below be required for a system, it is requested that the required measures be taken on the system side.

a) Unwanted Radiation (example)

FCC : PARTS15 CLASS B
 CISPR : CLASS B
 VCCI : CLASSB

b) Safety Standard (example)

IEC 60950
 UL 60950

7.7 Consultations on Doubtful and Unsettled Matters

Any actions to deal with any doubtful matters arise from or any matters not specified in this delivery specification shall be determined by both parties hereof after mutual consultations.